



FLUTROL

www.flutrol.com.br

Haskel[®]
INTERNATIONAL, INC.



**AIR PRESSURE
AMPLIFIER CATALOG**

OUR PRODUCTS ARE BACKED BY OUTSTANDING TECHNICAL SUPPORT, AN
EXCELLENT REPUTATION FOR RELIABILITY AND WORLDWIDE DISTRIBUTION





Haskel International, Inc. has almost 50 years of hydraulic and pneumatic engineering experience in the design and manufacture of a wide range of high pressure generating equipment and controls.

Located in Burbank, California, U.S.A., with additional manufacturing facilities in Sunderland, England, Haskel is supported by a worldwide network of offices and distributors.

Haskel air pressure amplifiers offer the most comprehensive range in the industry combining simple principles of operation with rugged construction suitable for the most demanding industrial applications.

Continuous investment in the most modern machinery and technology keeps Haskel the leader in this field.

Why use Haskel Air Amplifiers?

An alternative to the purchase of a dedicated high pressure compressor, Haskel air amplifiers are compact, require no electrical or mechanical drive connections, are powered by the same air that they amplify, and can be mounted in any position.

Key Features

- Infinitely variable outlet pressure and flow capability.
- No heat, flame or spark risk.
- No air line lubrication required eliminating oily exhaust.
- Long seal life and easily maintained.
- Wide range of models, controls, and options.
- Wide range of standard and custom systems.

TABLE OF CONTENTS

Introduction to Haskel	2
What is a Haskel Air Pressure Amplifier	3
Using Performance Curves	4
Sizing Air Amplifiers	5
Operation Guidelines	6
Air Amplifier Selection Chart	7
HAA-31 Series Performance, Controls & Options	8
HAA-31 Series Dimensional Data	9
4AAD-2 Series Performance, Controls & Options	10
4AAD-2 Series Dimensions	11
AAD-2 Series Performance	12
AAD-5 Series Performance	12
AA Series Performance	12-13
AA Series Controls & Options	14-15
AA Series Dimensional Data	16
8AAD-2 Series Performance, Controls & Options	17
8AAD-2 Dimensional Data	18
Typical Applications	19

WHAT IS A HASKEL AIR PRESSURE AMPLIFIER

An Air Pressure Amplifier is an air pump that is driven by part of the incoming compressed air supply enabling it to cycle and pump the balance of the supply to a higher output pressure.

Pressure is generated by the use of a differential area piston assembly. Low pressure air applied to a large area creates high pressure air on the small area. Cycling is achieved through the use of two pilot valves that alternately pilot and vent the large area end of a cycling spool. The small area end of the cycling spool uses a permanent air spring. This unbalanced cycling spool ensures that the air amplifier cycles on demand.

Unique Haskel seal technology enables the drive section of its pressure generating products to operate without air line lubrication. No lubrication of any kind is used in the high pressure

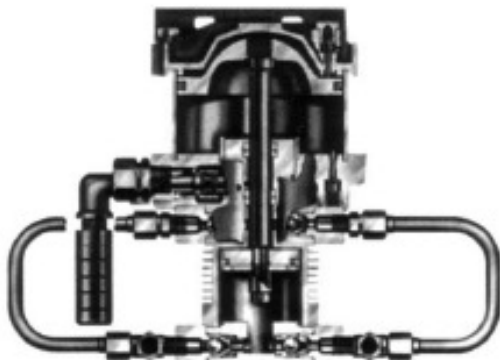

AAD-5

sections where non-metallic bearings and wear compensating seals are employed.

The ratio of the areas between the connected pistons is called the area ratio and is the dash

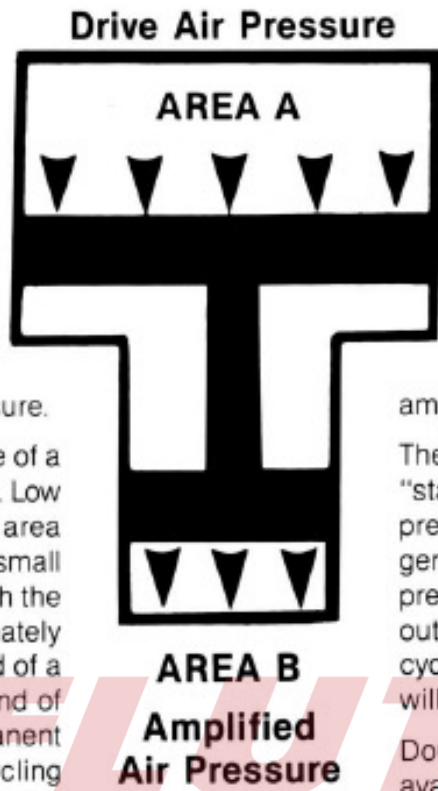

A:B IS NOMINAL AREA RATIO

number used in all model codes. This ratio and the available air drive source pressure determines the maximum outlet pressure of the air

amplifier.

The completely sealed air amplifier will "stall" at its maximum capable outlet pressure and consume no energy or generate any heat while doing so. When pressure drop is seen at the air amplifier outlet, the unbalanced spool ensures cycling to make up the pressure loss and will again "stall" after having done so.

Double acting and two stage models are available which provide increased output and efficiency as well as using input air directly on the high pressure piston(s) in both stroke directions to increase drive force and output pressure capability.

A proven range of horsepower sizes is available to meet most high pressure air requirements; from our 1/3 HP for low flow/static applications to our 8 HP used for high flow dynamic applications.

Haskel air pressure amplifiers are powered and controlled by the same compressed air they boost (amplify), with no electrical connections. And their minimal overall size makes them easy to install.

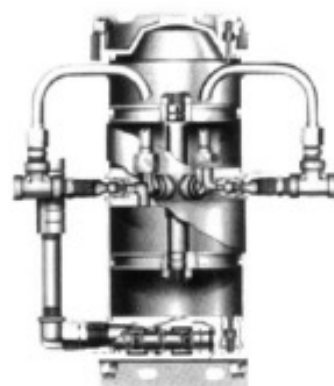

AAD-2

USING PERFORMANCE CURVES

MODEL AAD-2

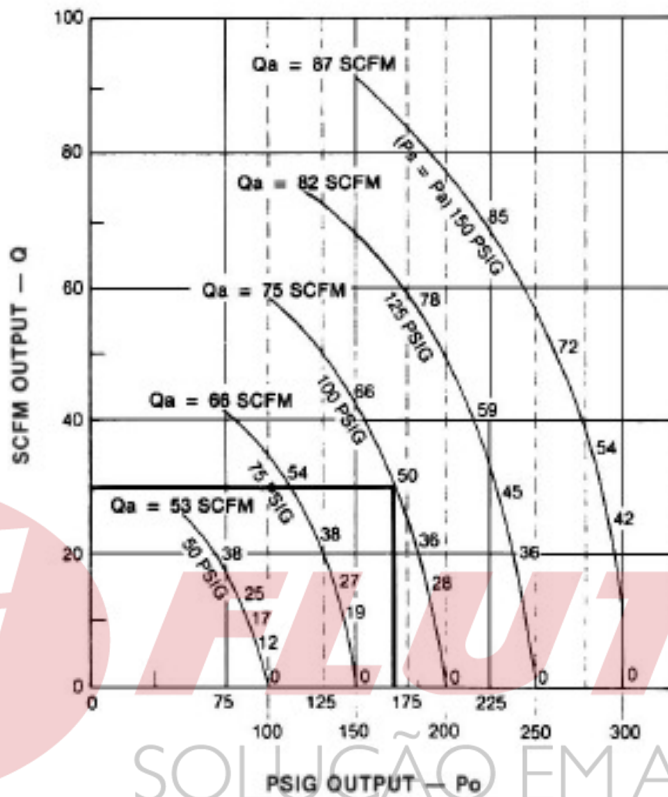

CONVERSION:
 1 bar = 14.5 psig
 1 normal cubic meter
 per minute = 35.31 scfm

SOLUÇÃO EM ALTA PRESSÃO!

All Haskel air amplifiers are variable pressure, variable flow devices within the limits of their sizes and ratios. Outlet pressure can be controlled by regulating the air drive and/or air supply pressure (depending on model) while outlet flow can be controlled by adjusting the air flow to the drive piston with a corresponding change in cycle rate.

Performance curves are provided for the various ratios for each horsepower size. The curves provide performance data for the most commonly requested parameters. Performance values for other parameters can either be interpolated from the curves provided or your local Haskel representative can assist you with specific performance data generated by our computer performance program.

Note that as the outlet pressure increases, flow decreases. The maximum outlet pressure is a

zero flow condition known as "stall" where the amplifier is maintaining pressure downstream. When it senses a drop in the downstream pressure, it will automatically cycle (the benefit of the unbalanced cycling spool) to raise the system pressure to the "stall" condition again, provided the consumption of air resulting in the pressure drop is within the flow capacity of the model selected.

The curves are easily read by comparing the required outlet pressure with the (available) air drive/supply curve and meeting the corresponding outlet air flow. The total required air volume will be the sum of both the outlet flow and the air drive consumed to cycle the air amplifier ($Q + Q_a = \text{total air volume required}$). In the example shown: $P_s = 100 \text{ PSIG}$, $P_o = 170 \text{ PSIG}$, $Q = 30 \text{ SCFM}$, $Q_a = 50 \text{ SCFM}$ (total air volume required is 80 SCFM).

Several factors are involved in the proper sizing of Haskel air amplifiers. Some involve the specific parameters of the application while some involve the application itself.

Specific parameters include:

- What is the outlet pressure required (P_o)?
- What is the *minimum* available air drive pressure (P_a)?
- What is the available air drive flow (Q_a)?
- What is the supply pressure (P_s)? (In most cases, $P_a = P_s$)
- What is the required flow (Q) at the outlet pressure?

Application data includes:

- What is the duty cycle?
- What is the high pressure required for?
 Testing — what is the volume of the vessel and time required?
 Part ejection — what is the cycle of volume requirements?
 Actuation — what is the bore & stroke of the actuator(s)?
 - single or double acting?
 - is high pressure air required on each stroke (double acting)? Which stroke?
 - is high pressure air required for the entire stroke length(s)?
 - what are the cycle requirements?

Dividing the outlet pressure (P_o) by the drive pressure (P_a) will provide us with the *minimum* area ratio of the amplifier(s). (The dash number

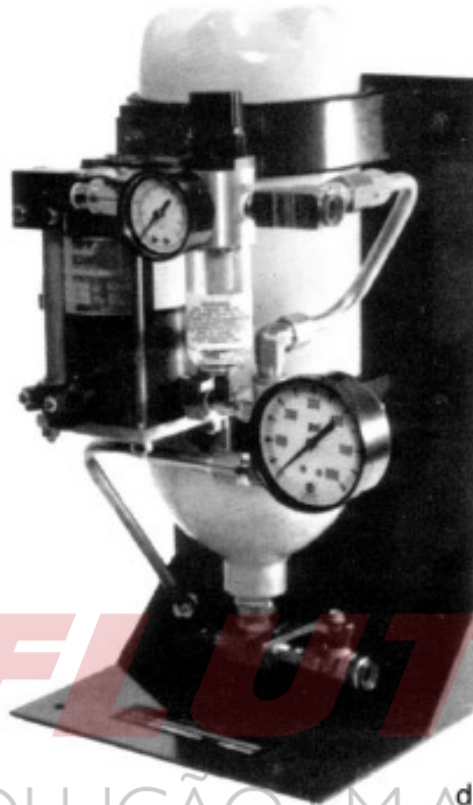

in the model code represents the area ratio.) More than one amplifier may be required: in certain high flow or heavy duty applications two or more amplifiers can be used in parallel; in certain higher flow/high pressure applications, a two-stage amplifier or multiple amplifiers can be used in series. Haskel offers a range of standard multipump units. Multipump units are most effective when the models selected produce the same flow for their respective pressure amplification.

We should verify the determination of flow required (Q) by evaluating the application data.

Finding that high pressure air is required only at the end of stroke or only on one stroke of the cycle may reduce the initial assessment of Q .

The outlet pressure and flow required can be compared to the performance curves. Familiarity with the flow capacities of the various sizes will soon enable you to compare flow required to the proper size when more than one for the necessary area ratio is available (ie., HAA-31-2.5, 4AAD-2, AAD-2, 8AAD-2).

Another consideration will be whether an air receiver used downstream can reduce the size of the amplifier required when the system cycle is taken into account (use high pressure air from the receiver during the on cycle and recharge the receiver during the off cycle) or enable momentary high flow requirements that initially are thought to exceed the capacity of our units. Haskel offers system options that include air receivers and controls.

OPERATION GUIDELINES

While Haskel manufactures air amplifiers for a wide range of pressures, care must be taken when sizing units for high outlet pressure applications. All air contains moisture and as you compress air, the moisture level does not reduce along with the volume of the air. The result is the same volume of moisture in a reduced volume of air. This saturation can lead to excessive maintenance for the air amplifier and the system. Dry, inexpensive gases such as nitrogen can be effectively used in the high pressure sections for these higher outlet pressure requirements (600PSIG and higher for example). For critical gas quality, refer to the use of our gas booster compressors which feature separation between drive and high pressure sections.

Other considerations include cycling rate and operation in unloaded conditions (i.e., before supply pressure has equalized or with small differential between supply and outlet pressures). Proper sizing of the air amplifier will avoid regular operation where the outlet pressure is too small of a percentage of the maximum outlet pressure

capability for the drive and supply pressure conditions. Cycling rate will be a factor of outlet pressure but can also be controlled by "throttling" the air drive volume. Various manual and automatic controls are available to prevent "no load runaway" and are illustrated in sections of this catalog pertaining to their respective drive series.

Maximum cycle rate is a factor of drive piston size, cycling mechanism, drive pressure, etc., and varies according to drive series. The maximum outlet flow and cycling speed are represented on the performance curves at the point where the outlet pressure and supply/drive curves intersect. These maximum cycling rates are not recommended for continuous duty (where the pressure and flow requirements for a system are constant) and the air amplifier performance should be derated for these applications to approximately 50% of maximum. Cycling speed at a given outlet flow can be calculated by dividing the **SCFM** outlet flow by the **SCF** ("free air volume") displacement per cycle.

SOLUÇÃO EM ALTA PRESSÃO!

$$\text{SCF/Cycle} = \frac{D_b}{1728} \times \frac{P_s + 14.7}{14.7} \times 0.85$$

Where: D_b = Displacement per cycle (cu. in.)
 Dividing by 1728 provides **Actual Cubic Foot** displacement
 P_s = Supply pressure
 Adding & dividing by 14.7 converts to **Absolute Atmospheres**
 0.85 = Efficiency factor (approximate)

When the maximum outlet flow from a performance curve has been determined, it can be converted to cycling speed (divide SCFM by SCF/Cycle). This cycling speed can then be derated for a continuous duty application and converted to rated continuous outlet flow (multiply

SCF/cycle × derated cycle speed) for improved seal life. Multiple units can be used in parallel if necessary to meet required outlet flows and maintain acceptable cycle rates for continuous duty applications.

AIR AMPLIFIER SELECTION CHART

DRIVE SIZE In (mm)	MAX AIR DRIVE PSIG (kPa)	MODEL	RATIO	MAX INLET PSIG (kPa)	MAX OUTLET PSIG (kPa)	DISPL/ CYCLE In ³ (ML)
2.87 (73)	125 (862)	HAA31-2.5	2.5:1	125 (862)	320 (2206)	2.40 (39.3)
2.87 (73)	125 (862)	HAA31-3.5	3.5:1	125 (862)	450 (3103)	1.77 (29.0)
2.87 (73)	125 (862)	HAA31-4.5	4.5:1	125 (862)	600 (4137)	1.35 (22.1)
4 (102)	125 (862)	4AAD-2	2:1	250 (1723)	250 (1723)	62.5 (1024)
5.75 (146)	150 (1034)	AA-8	8:1	1250 (8618)	2500 (17236)	13.2 (216)
		AA-15	15:1	2250 (15513)	2250 (15513)	6.2 (101)
		AA-30	30:1	4500 (31026)	4500 (31026)	3.1 (51)
		AAD-2	2:1	300 (2068)	300 (2068)	201 (3294)
		AAD-5	*5:1 (4:1)	1250 (8618)	1250 (8618)	19.3 (316)
		AAD-15	15:1	2500 (17236)	2500 (17236)	12.4 (203)
		AAD-30	30:1	4500 (31026)	4500 (31026)	6.2 (101)
		AAT-7/30	7/30	300 (2068)	4500 (31026)	13.2 (216)
		AAT-15/30	15/30	1000 (6895)	4500 (31026)	6.2 (101)
		AAT-30/50	30/50	3000 (20684)	5000 (34474)	3.1 (51)
8 (203)	130 (896)	8AAD-2	2:1	300 (2068)	300 (2068)	400 (6555)

MODEL NUMBER CODES

HAA31 Single acting, single stage air pressure amplifier.

& AA Maximum Po ("Stall") = Pa x Ratio

AAD Double acting, single stage air pressure amplifier provides outlet flow on each stroke of cycle and gains "lift" from inlet pressure.

Maximum Po ("Stall") = Pa x Ratio + Ps (*Often Pa = Ps)

AAT Two-stage air pressure amplifier provides two high pressure pistons of different ratios within a single unit for maximum efficiency at higher outlet pressures.

Maximum Po ("Stall") = Pa x Ratio 2nd Stage + Ps x Ratio Stages

HAA31 SERIES PERFORMANCE, CONTROLS & OPTIONS

HAA31-2.5

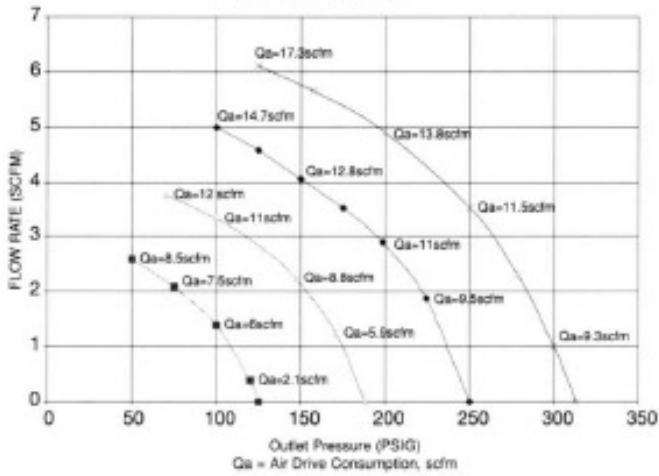

HAA31-3.5

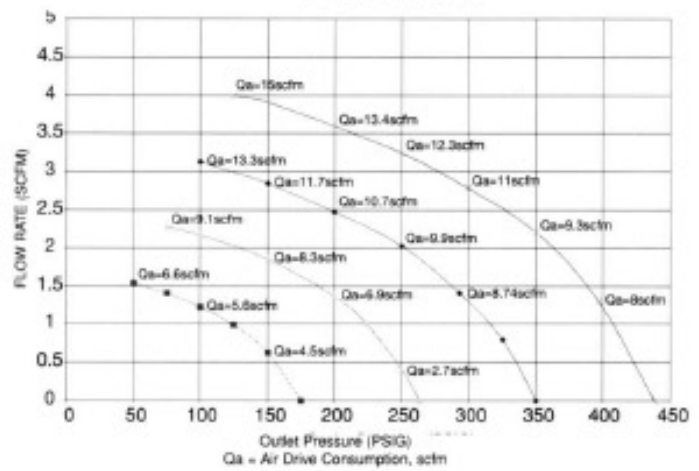

HAA31-4.5

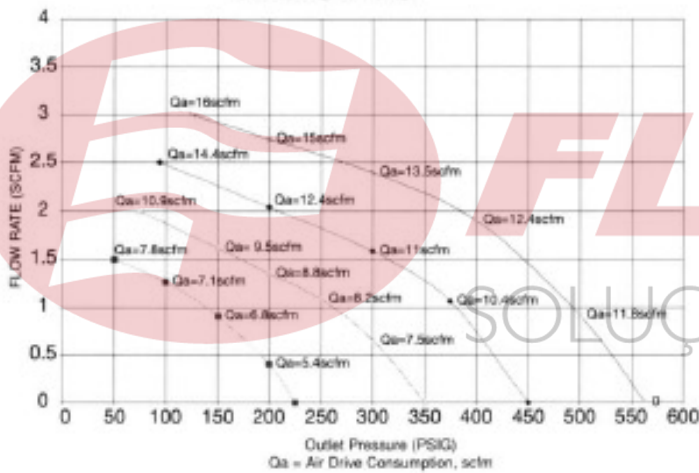

NUMBER	DESCRIPTION
85291	Receiver & Controls

HAA31-XX AIR AMPLIFIER CIRCUIT

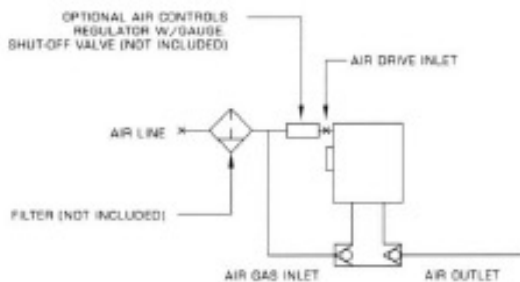

SYSTEM DIAGRAM FOR HAA31 AIR AMPLIFIER (85291-HAA31-XX)

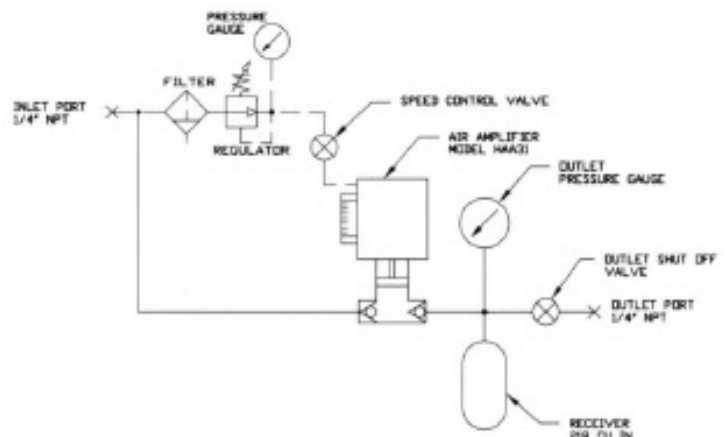

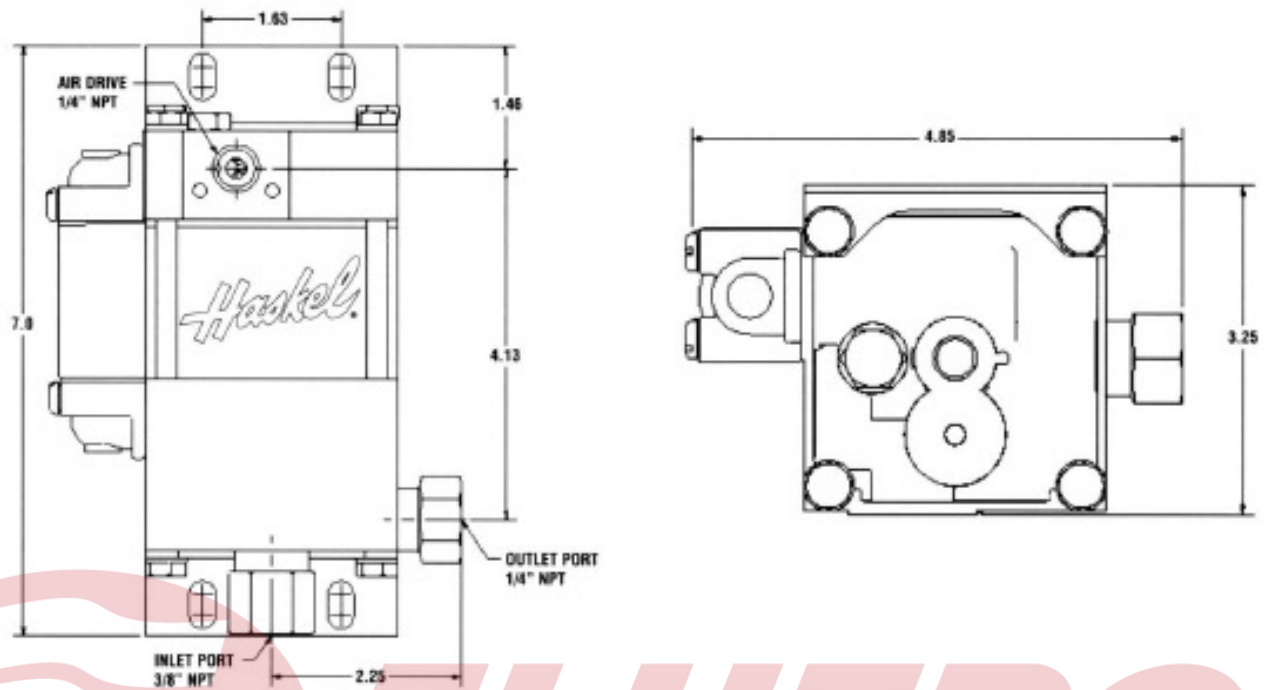
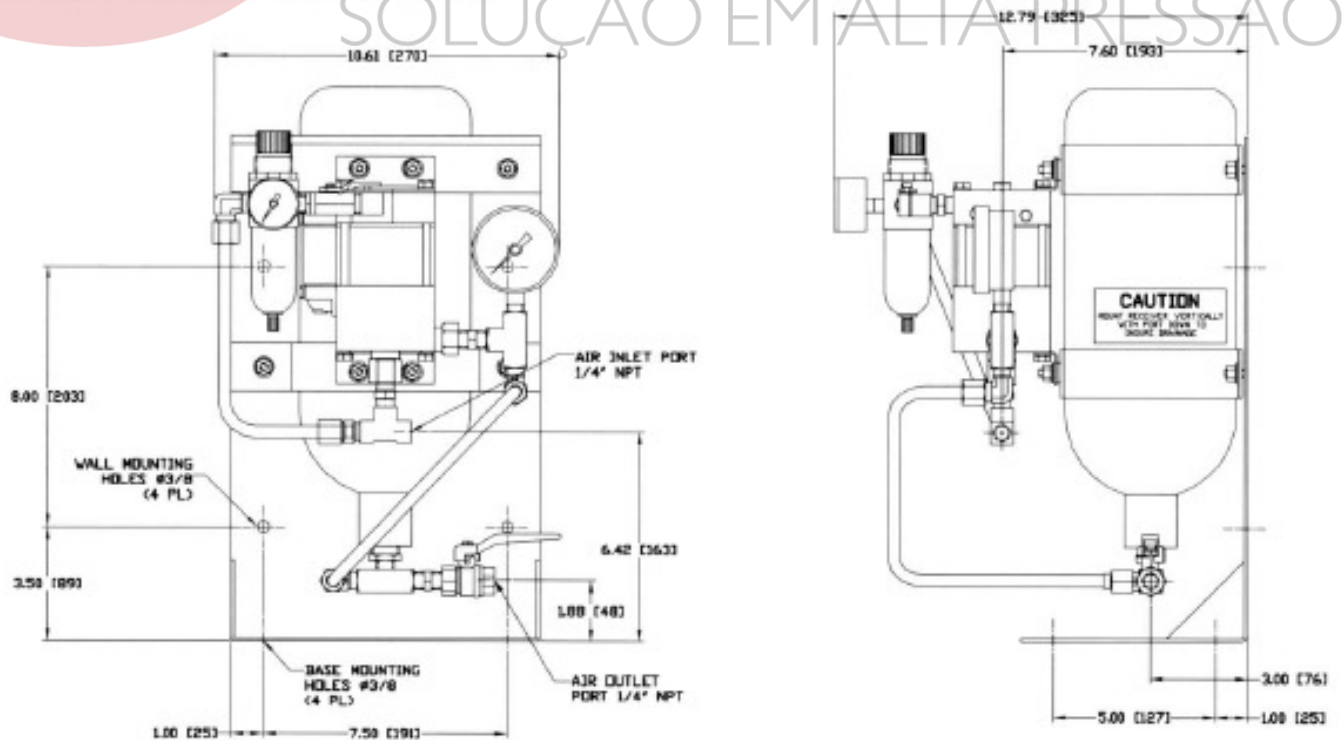
HAA31 SERIES DIMENSIONAL DATA
HAA31 SERIES

MODEL NO. 85291
HAA31 SERIES MINI SYSTEM

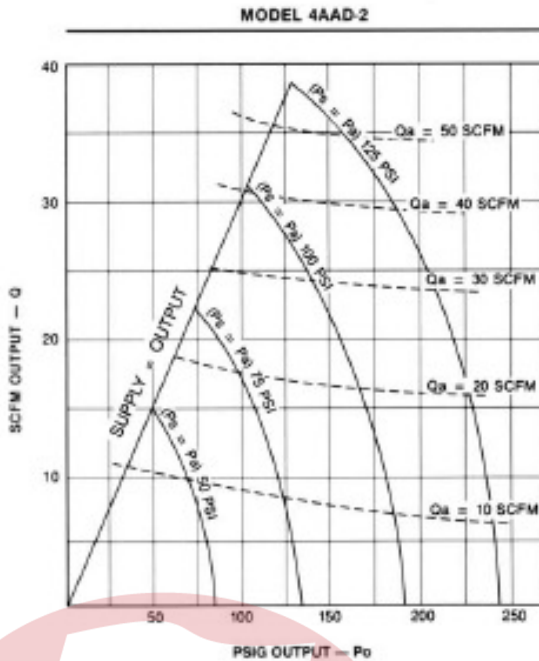
4AAD-2 SERIES PERFORMANCE, CONTROLS & OPTIONS



NUMBER	DESCRIPTION
-C	Air (F-R, Gauge & Valve) Controls
56594	External Pilot Modification
56569	No Load Run Away & Regulator
56564	Extreme Service Cycling Mod
56570	Receiver & Controls

NOTE: Total input air volume required = Q + Qa

CONVERSION:

1 bar = 14.5 psig

1 normal cubic meter per minute = 35.31 scfm

FLUTROL

56570

SOLUÇÃO EM ALTA PRESSÃO!

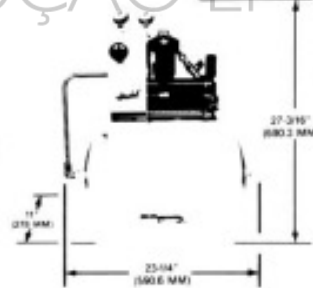
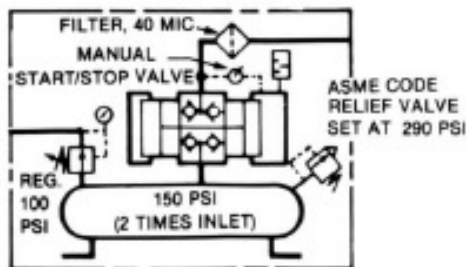

MODEL 56570
for 4AAD-2 on 5 1/4 gal., 290 psi ASME code receiver with controls and ASME relief valve.

56569

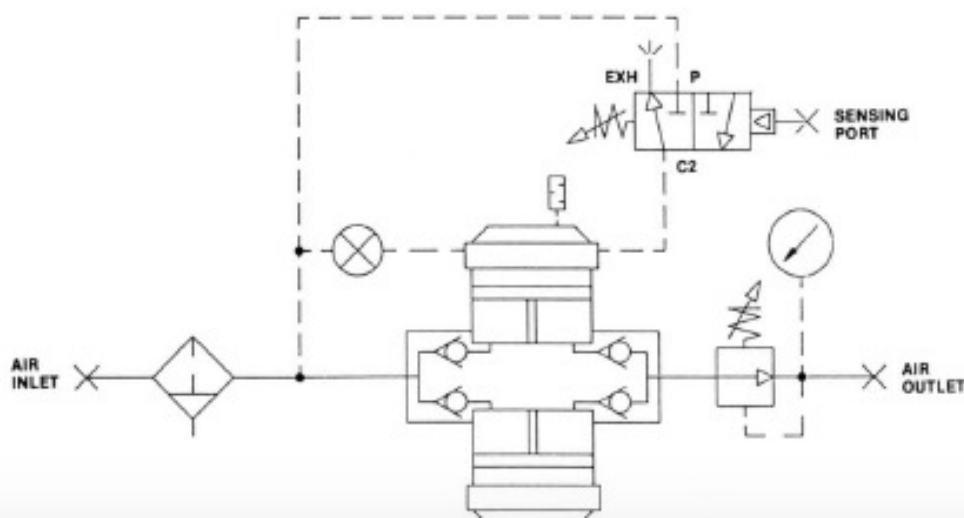

4AAD-2 SERIES DIMENSIONS

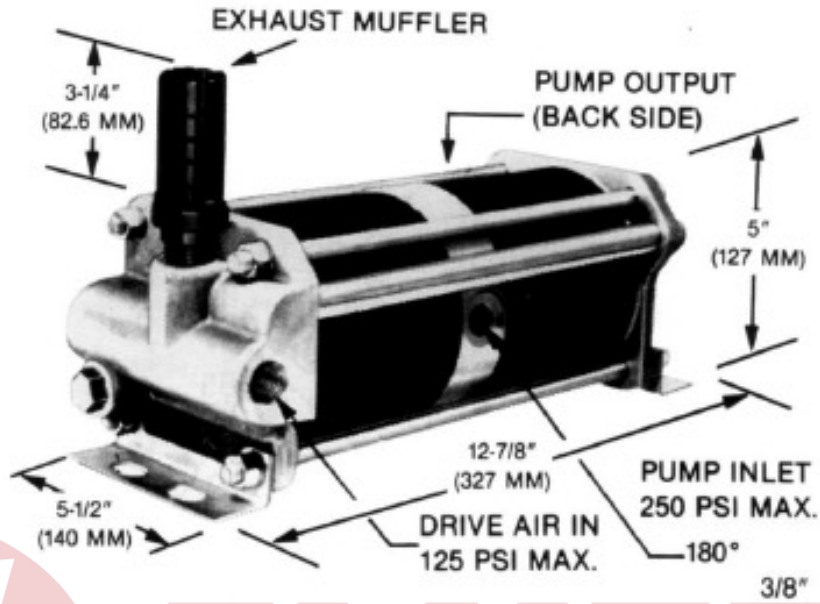

56570

FLUTROL

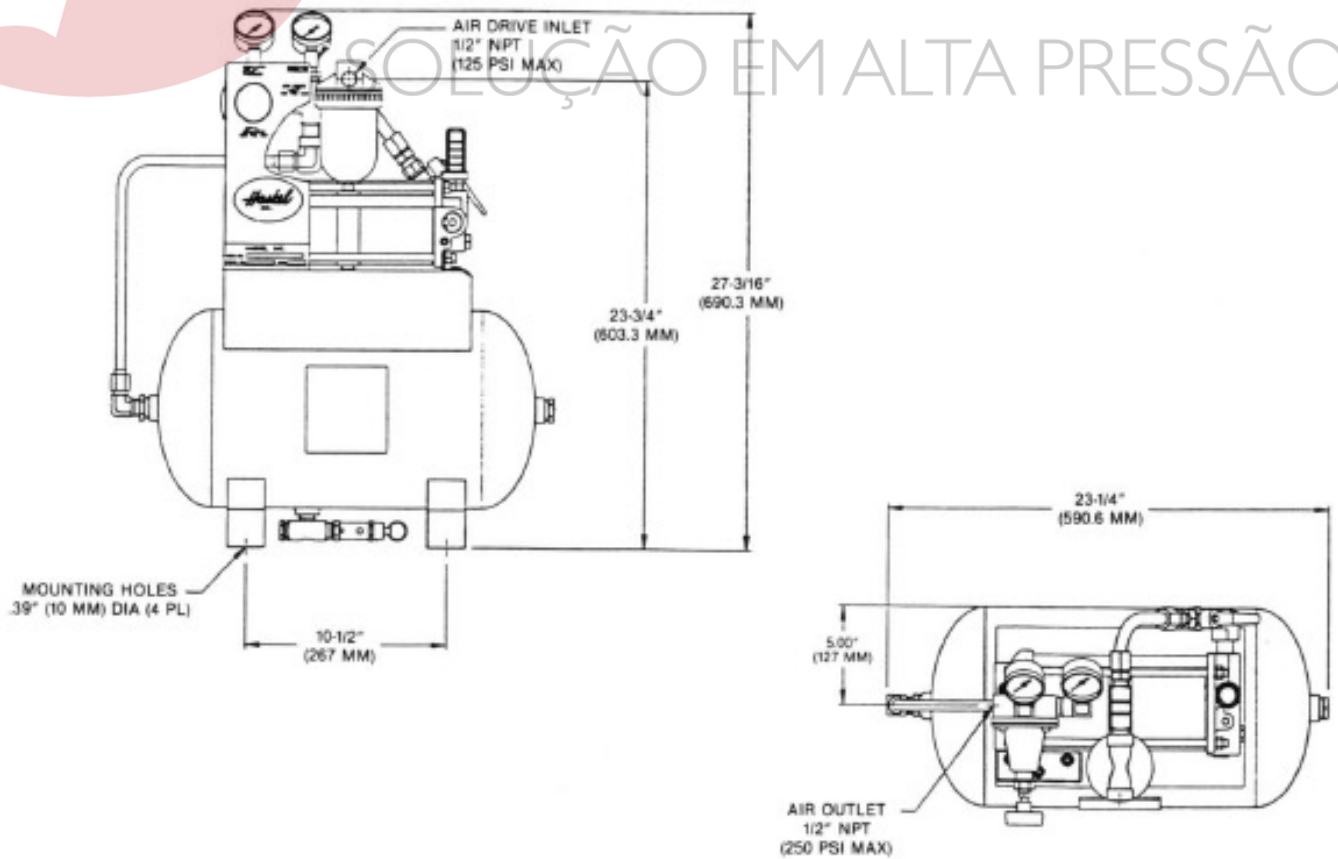

AA-2, AAD-5 PERFORMANCE

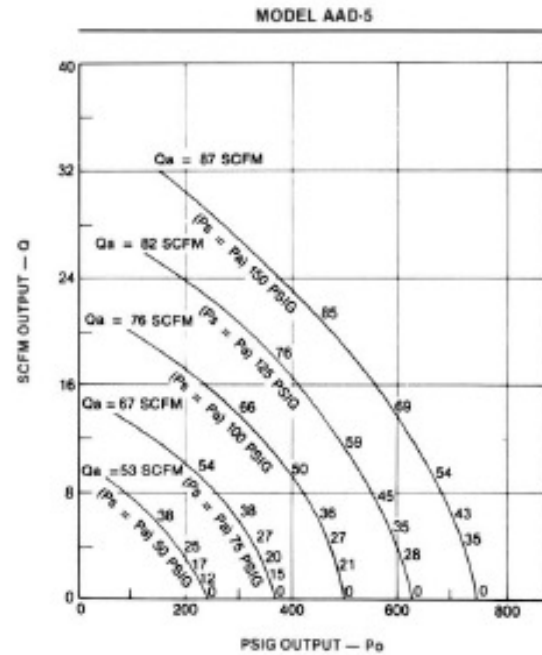
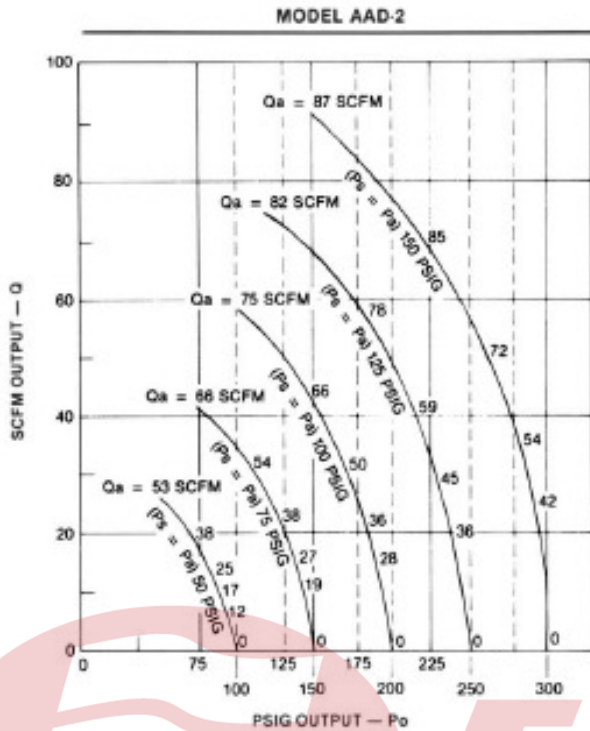

AA SERIES PERFORMANCE

The following models are often used in applications where the drive pressure, P_a , is regulated below a higher supply pressure, P_s , (e.g., if bottled nitrogen is supply and plant air is drive). The shaded areas on three charts are beyond rated maximum working pressure.

MODEL AA - 8

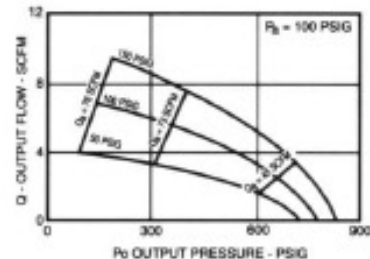
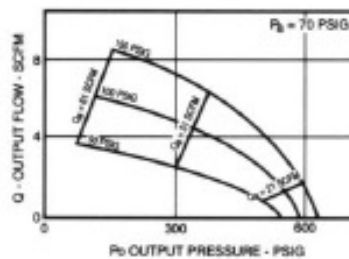
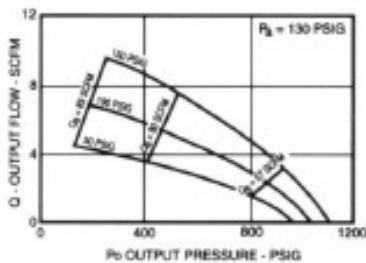

MODEL AA - 15 Single Acting - Single Stage

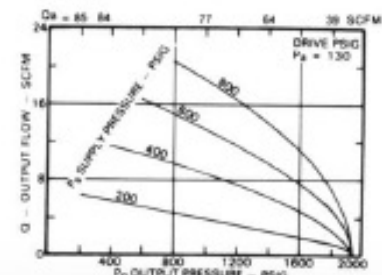
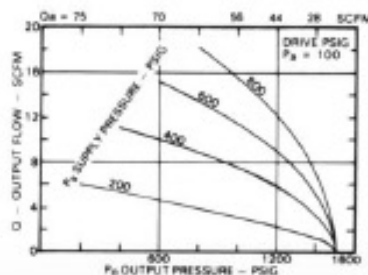
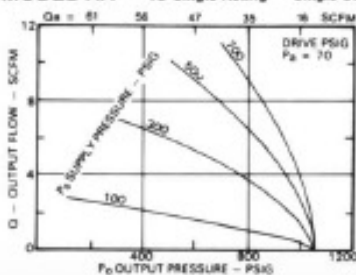

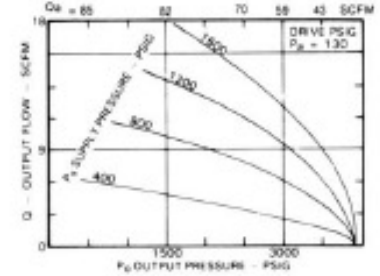
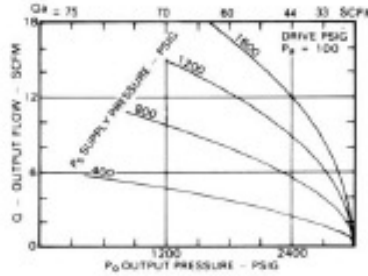
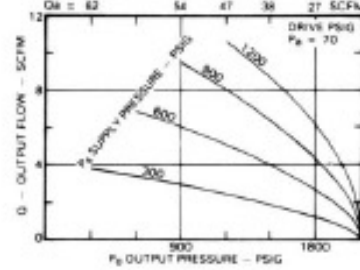
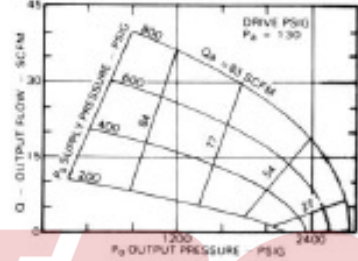
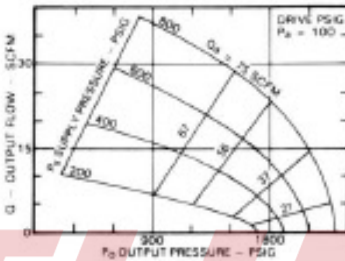
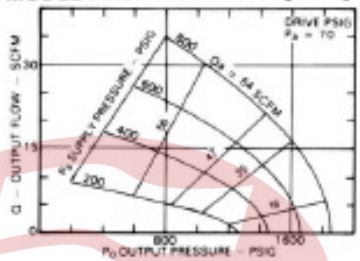
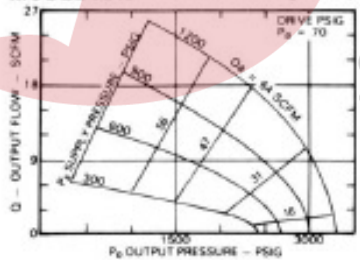
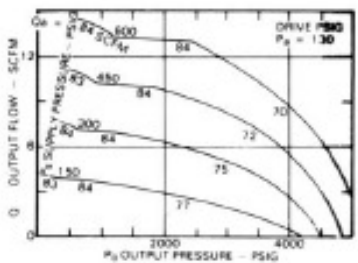
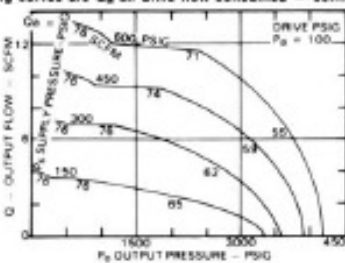
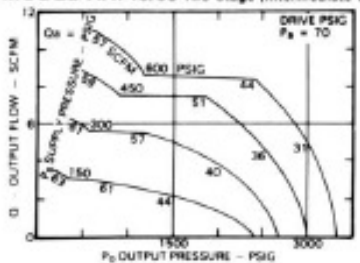
MODEL AA — 30 Single Acting — Single Stage

MODEL AAD — 15 Double Acting — Single Stage

MODEL AAD — 30 Double Acting — Single Stage

MODEL AAT-15/30 Two Stage (Intermediate numbers along curves are Qa air drive flow consumed — scfm.)

CONVERSION:

1 bar = 14.5 psig

1 normal cubic meter per minute = 35.31 scfm

NOTE: *Total input air volume required = Q + Qa
 *Consult factory for model AAT-7/30 performance data.

AA SERIES CONTROLS & OPTIONS

All models are available with factory installed controls at extra cost. There are many control options. Details will vary depending on pressures and application requirements and which amplifier models are used. The schematics and charts below describe some of the more common options.

Note that options 3 and 4 control start/stop with external pilot air. Any model can be converted to cycle with external pilot air only. (Specify modification No. 28881.)

NUMBER	DESCRIPTION
-C	Air (F-R, Gauge & Valve) Controls
28881	External Pilot Modification
-MA1	28881 & Air Pilot Switch
17860	Electrical Stroke Counter
25721	Mechanical Stroke Counter
29376	Three Way Cycling Spool
29702	Single Stroke Modification

NUMBER	DESCRIPTION
29960	AAD-2 Receiver and Controls
51050	Extreme Service Cycling Mod
53375	125PSIG Downstream Regulator AAD-2
53375-1	200PSIG Downstream Regulator AAD-2
53376	Regulator, Air Pilot Switch, and Relief Valve AAD-5

SOLUÇÃO EM ALTA PRESSÃO!

STANDARD AIR CONTROLS — All Models

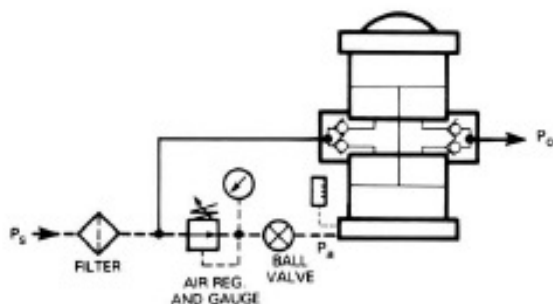

Specify Using	Provides	Remarks
-C after model number	Rough max. P_o control by regulating P_a only if P_s is constant.	Regulation of P_a will reduce peak performance.

SEMI-STANDARD AIR CONTROLS — AAD-2 Only

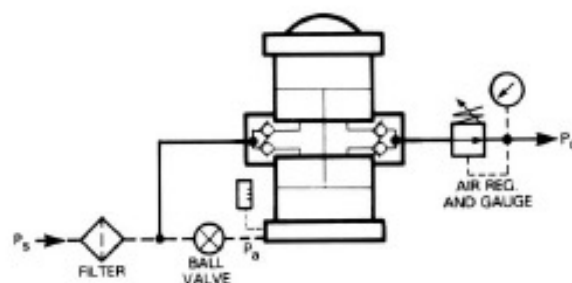

Specify Using	Provides	Remarks
-53375 before model AAD-2-C	Good max. P_o control with peak performance. Max. reg. P_o 125 psi. 200 psi spring optional.	Max. input to reg. is 300 psi. Therefore, use AAD-2 only.
-53375-1	Optional 200 psi spring.	

AA SERIES CONTROLS & OPTIONS

NORMALLY OPEN AIR PILOT SWITCH With Relief Valve and Air Controls — AAD-5

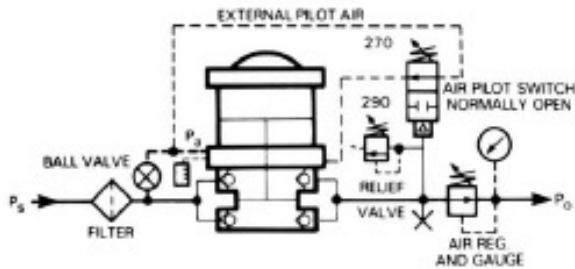

Specify Using	Provides	Remarks
—53376 before model AAD-5	Good max. P_o control to 200 psi with port to add 1-1/2 or 5 gal. ASME receiver (290 psi).	Good selection where P_s falls into 60–80 psi range.

NORMALLY CLOSED AIR PILOT SWITCH — All Models To Prevent No-load Runaway

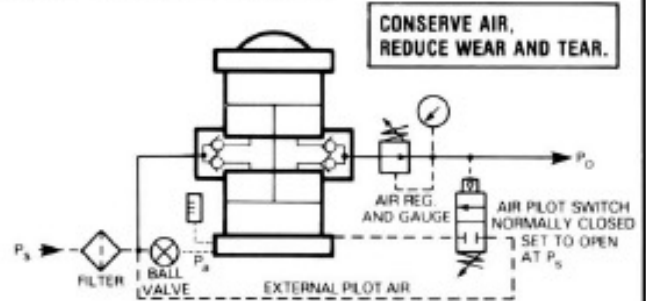

Specify Using	Provides	Remarks
MA-1 (after model number) and requested setting within 50-180 psi (increasing range, e.g. AAD-2MA-1 set at 70 psi increasing)	Anchor on drive so unit will not start until P_s has equalized throughout system.	Reduces maintenance. Locate air pilot switch as close to work as possible. May be added to any schematic 1–5.



ASME CODED 15 GALLON RECEIVER WITH CONTROLS — AAD-2 Only

Model 29960 is a complete pneumatic system designed to provide amplified pressure and momentary high flow. It utilizes available plant air (up to 95 psi) to both the supply and drive inlets of the model AAD-2 which automatically stalls once the storage tank has been filled to about double the supply pressure. The amplifier will sense any use of air from the tank, and resume operation again to stall at about 2 times supply pressure. The regulator on the tank output is provided to control the output pressure and flow, up to about (momentarily) 150 scfm. Also included is an ASME coded safety relief valve on the tank set at 200 psig.

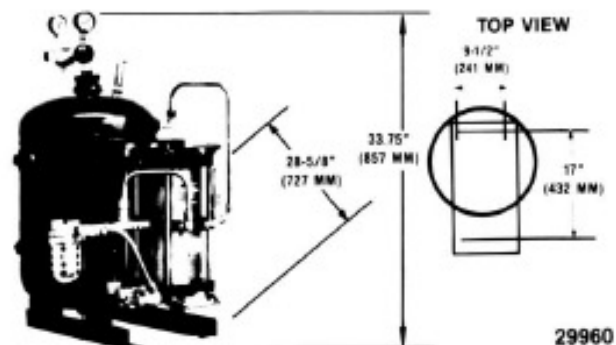

29960

AA SERIES DIMENSIONAL DATA

MODEL	IN-PORT	OUT-PORT	A DIM	B DIM	C DIM
AA-8	3/8" NPT	3/8" NPT	14-3/4" 325mm	9-3/4" 248mm	9-1/4" 235mm
AA-15	1/4" NPT	1/4" NPT	14-3/4" 325mm	9-3/4" 248mm	9-1/4" 235mm
AA-30	1/4" NPT	1/4" NPT	14-3/4" 325mm	9-3/4" 248mm	9-1/4" 235mm
AAD-2	3/8" NPT	3/8" NPT	16-5/8" 422mm	14" 356mm	15-1/2" 394mm
AAD-5	1/2" Tube	1/2" Tube	12-1/4" 311mm	18-1/2" 470mm	7" 128mm
AAD-15	1/4" NPT	1/4" NPT	21-5/8" 549mm	9-1/2" 241mm	9-1/8" 232mm
AAD-30	1/4" NPT	1/4" NPT	20-1/2" 521mm	9-1/2" 241mm	9-1/8" 232mm
AAT-7/30	3/8" NPT	1/4" NPT	21-1/4" 540mm	12-3/4" 321mm	9-1/8" 232mm
AAT-15/30	1/4" NPT	1/4" NPT	21-1/4" 540mm	12-3/4" 321mm	9-1/8" 232mm

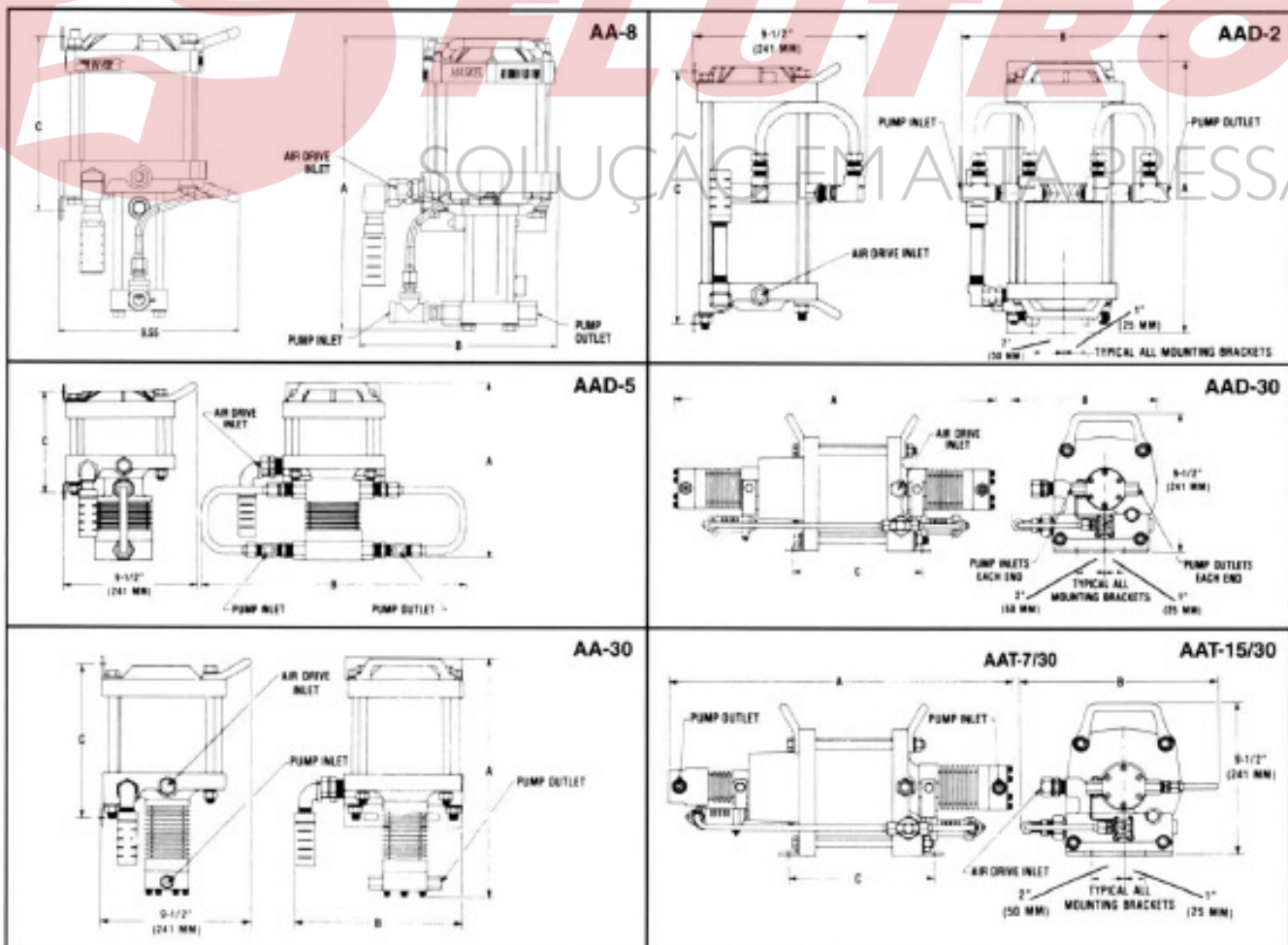

8AAD-2 SERIES PERFORMANCE, CONTROLS & OPTIONS

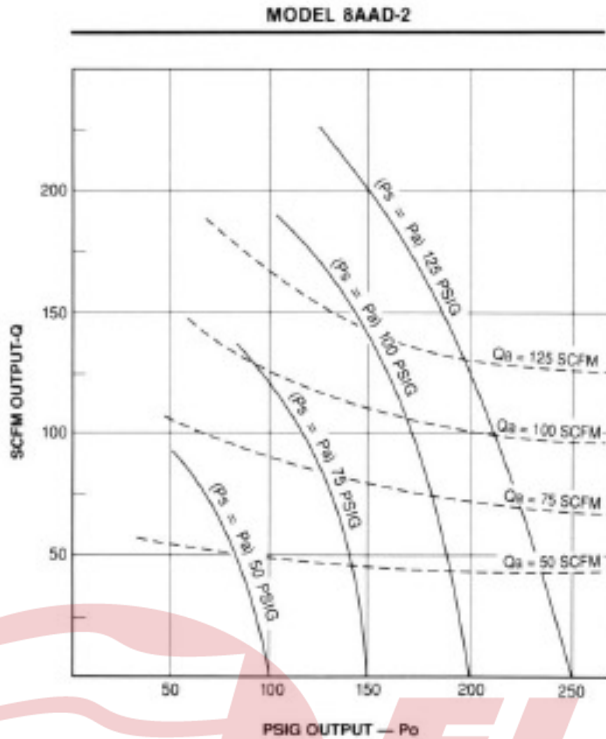

NUMBER	DESCRIPTION
-C	Air (F-R, Gauge & Valve) Controls
29125	External Pilot Modification
-MA1	29125 & Air Pilot Switch
17860	Electrical Stroke Counter
25721	Mechanical Stroke Counter
29702	Single Stroke Modification
54312	Extreme Service Cycling Mod
59790	No Load Run Away Mod
59791	59790 With Air Controls
59462	8AAD-2 With Receiver and Controls

NOTE: Total input air volume required = Q + Qa

CONVERSION:

1 bar = 14.5 psig

1 normal cubic meter per minute = 35.31 scfm

FLUTROL

SOLUÇÃO EM ALTA PRESSÃO!

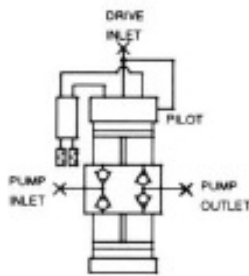

BASIC 8AAD-2

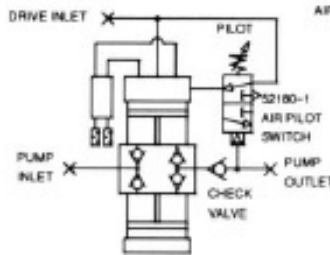

59790-8AAD-2

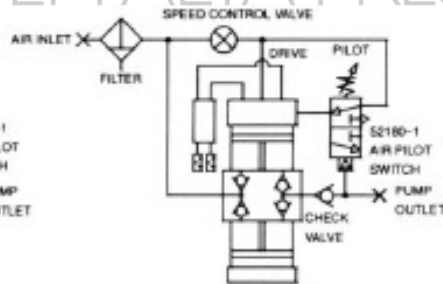

59791-8AAD-2

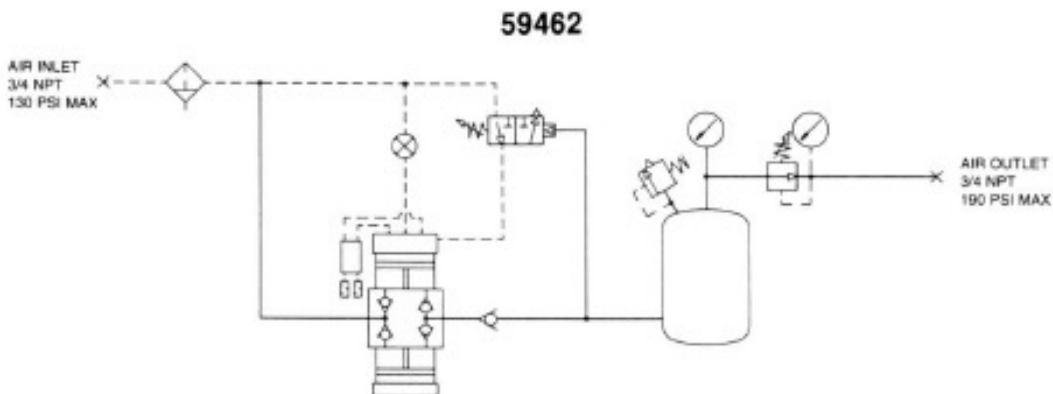

8AAD-2 DIMENSIONAL DATA

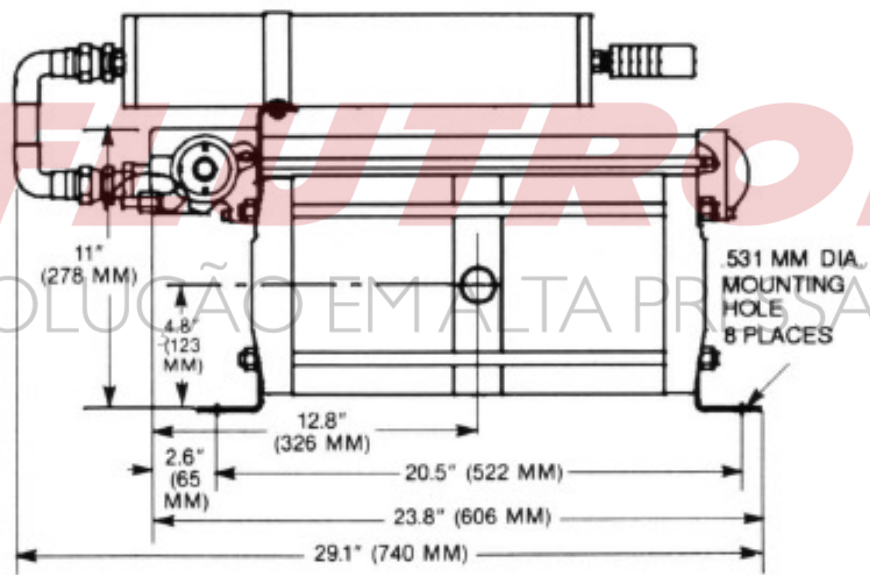
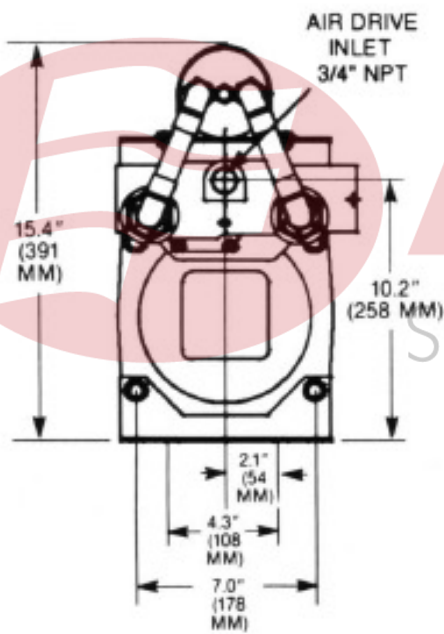
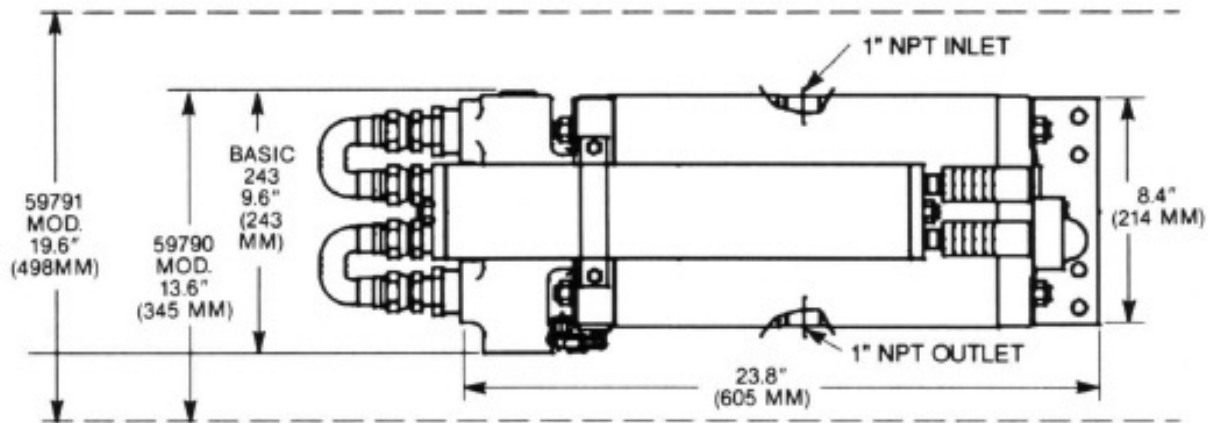

TYPICAL APPLICATIONS

AIR PRESSURE AMPLIFIERS

PRESSURE TESTING

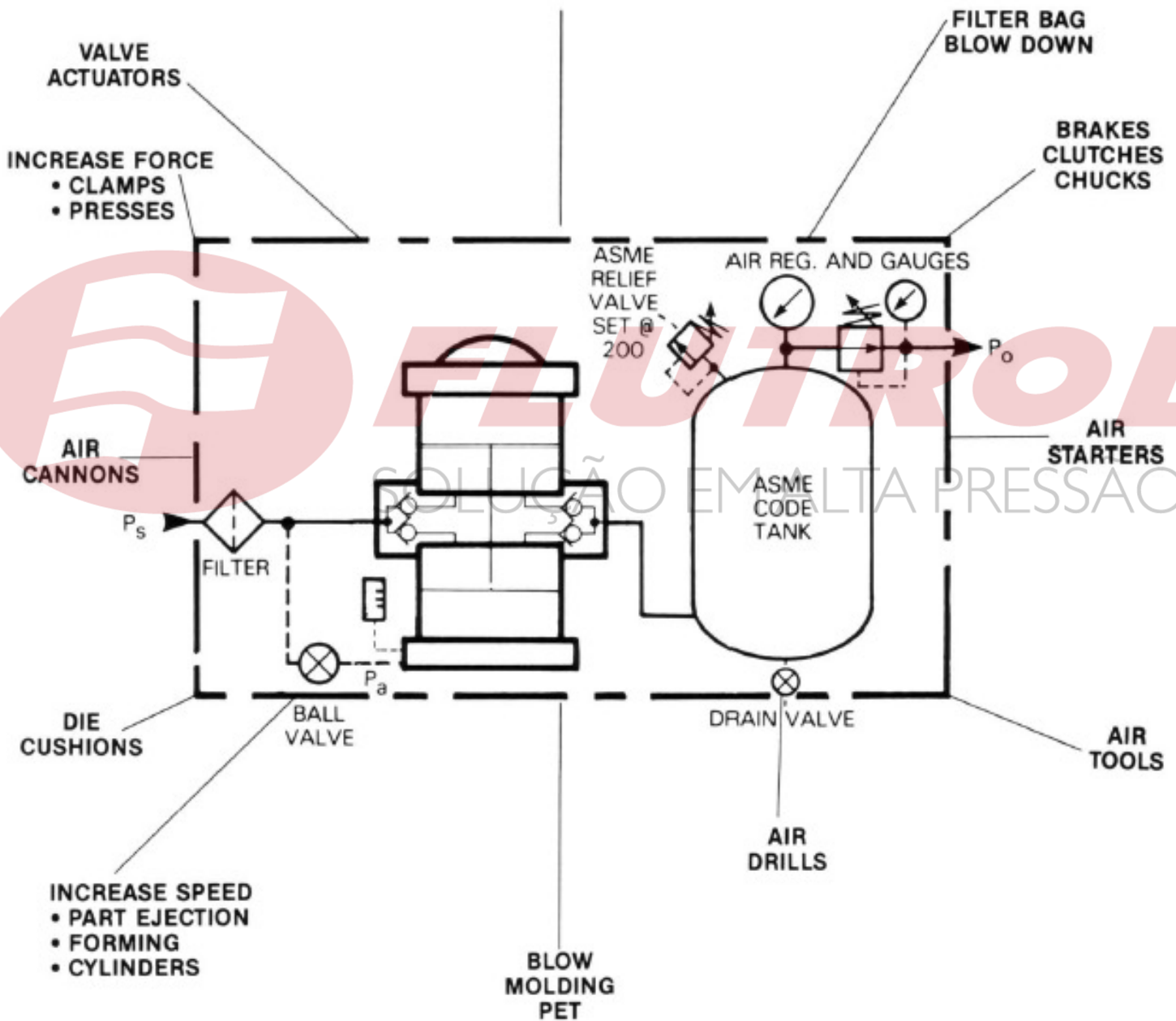



FLUTROL

SOLUÇÃO EM ALTA PRESSÃO!



Haskel International, Inc.
North America • South America
100 East Graham Place
Burbank, California 91502 • USA
Telephone: (818) 843-4000
Fax: (818) 556-2549 or (818) 841-4291



Haskel Energy Systems Ltd.
Europe • Middle East
North Hytton Road
Sunderland SR5 3JD • England • UK
Tel: 44-191-549-1212 • Fax: 44-191-549-0911

Haskel (Asia) Pte. Ltd.
23 Tagore Lane #03-07
Tagore 23 Warehouse Complex
Singapore 787801
Tel: 65-6455-7559 • Fax: 65-6455-2841

Haskel Australasia Pty. Ltd.
P.O. Box 267
Salisbury, Qld. 4107, Australia
Tel: 61-7-3277-9118 • Fax: 61-7-3277-6129

Haskel Hochdruck Systeme GmbH
D-46485 Wesel
Fritz-Haber Strasse • Germany
Tel: 49-281-98-48-00 • Fax: 49-281-98-48-020

Haskel-General Pneumatic
4 rue du haut de la Cruppe
F-59650 Villeneuve d'Ascq • France
Tel: 33-320-04 66 00 • Fax: 33-320-33 31 95

Haskel Benelux B.V.
Cobaltstraat 29
2718 RN Zoetermeer • Netherlands
Tel: 31-79-361 84 72 • Fax: 31-79-360 05 60

Haskel España S.R.L.
Paseo Urbarburu 81 • Edif. 5 • 1ª Planta
Locales 1 y 2 • Pol. 27 Martutena
20115 Astigarraga • Gipuzkoa • Spain
Tel: 34-943-47 45 66 • Fax: 34-943-45 11 86

Haskel Energy Systems Limited
Unit 14, Airways Industrial Estate,
Pittmedden Road
Dyce, Aberdeen AB21 0DT • Scotland
Tel: 01224-771784 • Fax: 01224-723642

Haskel Italiana S.R.L.
via Varese 17/B
21013 Gallarate • Varese • Italy
Tel: 0039 0331 701133 • Fax: 0039 0331 701130

For further information on
Haskel products, visit our
website at: www.haskel.com